

STULZ-SICKLES STEEL COMPANY

SINCE 1916

*Providing Years of Wear Resistant Service to the
Quarry and Heavy Construction Industries*



ELIZABETH, NEW JERSEY ♦ COLTON, CALIFORNIA
800-351-1776 800-572-5809
www.stulzsicklessteel.com www.manganal.com

STULZ SICKLES STEEL CO.

MANGANAL

HIGH MANGANESE HIGH CARBON STEEL

PHYSICAL PROPERTIES

Yield Strength 60,000/85,000 psi
Tensile Strength 120,000/130,000 psi
% Elongation in 2" 35%/50%
Hardness as Rolled 230 bhn
Work Hardens-up to 550 bhn

CHEMICAL ANALYSIS

Mn-12.0/14.0	Si-0.60 Max.
C-1.1/1.4	P-0.05 Max.
	S-0.04 Max.

CHARACTERISTICS

- RESISTS ALL IMPACT AND ABRASION
- WORK HARDENS RAPIDLY UP TO 550 BRINELL DUE TO HIGH CARBON CONTENT
- REMAINS DUCTILE THROUGHOUT, NEVER BRITTLE
- WORK HARDENED SURFACE BECOMES ALMOST FRICTIONLESS WHICH ALLOWS THE MATERIALS TO SLIDE EASILY
- HAS NON-MAGNETIC PROPERTY
- CAN BE CUT BY OXY-ACETYLENE TORCH, PLASMA, WATER JET, OR LASER

**WELD WITH STULZ MANGANESE-XL
OR STULZ 1616**

HADFIELD GRADE
FULLY HEAT TREATED
FULLY AUSTENITIC
ASTM A128

YEARS OF MANGANAL PROVEN PERFORMANCE IN:

- FRONT END LOADER LINERS
- ROCK TRUCK BED LINER KITS
- EXCAVATOR BUCKET FLOORS
- CRUSHER LINERS/JAW PLATES
- GRIZZLY BARS
- PERFORATED PLATES/ROCK SCREENS
- STONE CHUTES/TRANSFER POINTS

THIS IS WHY MANGANAL OUTLASTS OTHER MATERIALS:

- WORK HARDENS RAPIDLY TO 550 BHN
- THRIVES UNDER SEVERE IMPACT OR COMPRESSIVE LOADS
- NEVER BECOMES BRITTLE
- UNIFORM TOUGHNESS EQUALS UNIFORM WEAR
- VERY WELDABLE/FORMABLE
- CAN BE CUT WITH OXY-ACETYLENE AND PLASMA

. . . and any other places where heavy impact, abrasion or metal-to-metal wear is a problem.

FREQUENTLY ASKED QUESTIONS

WHAT IS UNUSUAL ABOUT MANGANAL?

Manganal thrives on severe wear conditions. The more impact and hammering it receives, the harder the surface becomes. This characteristic, known as work-hardening, plus the fact that it remains ductile underneath, makes it a most effective steel in combating impact and abrasion.

HOW HARD CAN THE SURFACE GET BY WORK-HARDENING?

Depending on deformation of the surface crystalline structure, it can work-harden up to more than 550 Brinell. When originally put into service it is about 230 Brinell.

HOW DOES MANGANAL BEHAVE UNDER IMPACT WITH NO ABRASION?

One example of surface work-hardening under almost pure impact are grizzly bars. Manganal work-hardens rapidly, takes a smooth polish due to its low friction property, yet retains its great toughness under the hardened surface. Generally, the heat-treated alloy and tool steels, although of high hardness, tend to erode comparatively fast, and break down on the surface.

HOW IMPORTANT IS THE CARBON CONTENT IN MANGANAL?

The carbon content is very important because when a Manganal plate is impacted, the carbon binds with the manganese and allows the surface to work harden. The result is less wear on the thickness of the plate prior to complete work-hardening. For manganese steel to be considered Hadfield grade, the carbon content must be 1.0% or higher.

HOW ABOUT MACHINING MANGANAL?

Manganal is machined within limits, using special methods and tooling. When a drill or cutting tool is applied to Manganal, it quickly work-hardens the area to the extent that machining becomes very difficult. Therefore Manganal does not lend itself to machining by usual machine shop methods.

WHAT METHODS ARE EASILY USED TO WORK MANGANAL?

It can be flame cut by oxy-acetylene torch, cut by abrasive cut-off machine and electric welded (minor preheating is recommended). Shearing, bending, and rolling require heavy equipment which has at least twice the capacity that would be needed for the same thickness of mild steel.

MANGANAL

WEAR RESISTANT HIGH MANGANESE STEEL APPLICATOR BARS AND PLATE

STULZ HADFIELD GRADE ♦ 12-14% MANGANESE ♦ 1.1/1.4 CARBON

FLATS						ROUNDS	SQUARES	PLATES
SIZE	SIZE	SIZE	SIZE	SIZE	SIZE	SIZE	SIZE	THICKNESS
3/16" x 2-1/2"	3/8" x 1"	1/2" x 1"	3/4" x 1-1/2"	1" x 1-1/2"	1-1/2" x 2"	3/8" 2-1/4"	3/8"	1/8"* 1-1/8"
1/4" x 1"	1-1/2"	1-1/2"	2"	2"	6"	1/2" 2-1/2"	1/2"	3/16" 1-1/4"
1-1/2"	2"	2"	2-1/2"	3"		5/8" 3-1/8"	5/8"	1/4" 1-3/8"
2"	2-1/2"	2-1/2"	3"	4"	2" x 3"	3/4" 3-1/2"	3/4"	5/16" 1-1/2"
2-1/2"	3"	3"	3-1/2"	5"	4"	7/8" 4-1/8"	1"	3/8" 1-5/8"
3"	4"	3-1/2"	4"	6"		1" 4-1/2"	1-1/4"	1/2" 1-3/4"
4"	4-1/2"	4"	5"	8"		1-1/8" 5-1/8"	1-1/2"	5/8" 2"
5"	5"	5"	6"			1-1/4" 5-1/2"	2"	3/4" 2-1/4"
	6"	6"				1-1/2" 6-1/8"		7/8" 2-1/2"
						1-3/4" 6-3/4"		1" 3"
						2" 7-1/8"		

FABRICATED PARTS TO PRINTS

WELDED, PUNCHED, DRILLED
AND FORMED FABRICATIONS WILL
BE QUOTED ON SUBMISSION OF
SKETCH OR BLUEPRINT SPECIFICATIONS.

ANGLES
2" X 2" X 1/4"

**PINS &
BUSHINGS**

STOCK PLATE SIZES

48" X 96"

48" X 144"

60" X 120"

72" X 144"

84" X 120"

96" X 240"

& Lengths up to 24 ft.

* 1/8" x 40" x 99"

CUSTOM MANGANAL PRODUCTS

MANGANAL IS WELDABLE



Manganal Wear Bars on
Bottom of Excavator Bucket

MANGANAL CAN BE FLAME CUT/PLASMA CUT



Manganal Grizzly Bars

MANGANAL IS FORMABLE

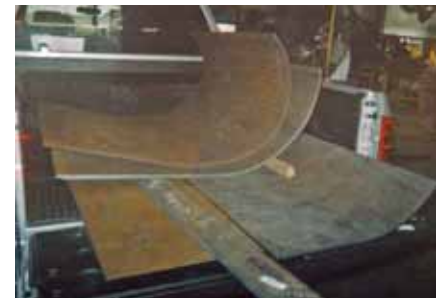

Manganal Bucket Liners

STULZ FABRICATIONS TO ORDER



MANGANAL PERFORATED PLATE

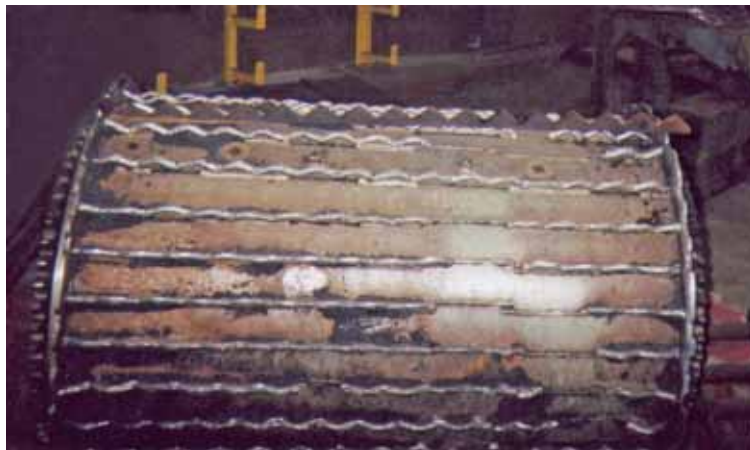

MANGANAL FEED ROLLER

MANGANAL PINS, BUSHINGS & CAST TUBING

- CUSTOM PRODUCED



STULZ FABRICATIONS TO ORDER

MANGANAL ROCK TRUCK BED LINER KIT



Truck Bed Liner (shown to the left) after three years in service showing little sign of wear

MANGANAL GRIZZLY BARS



Grizzly Bars (shown to the left) after two years of service. Prior to switching to manganal, the customer was building up bars yearly.

Manganal side plates show little wear after two years

MANGANAL LINER



REBUILT OUT OF MANGANAL



Original 400 BHN bucket liner held up for three months. Customer switched to manganal liner, floor, and sides which lasted a year and a half. Customer then rebuilt entire bucket out of manganal and reused original manganal liner which is still in use three years later.

UNIVERSAL PROCESSOR



Manganal teeth fabricated for processor before (shown to the left) demolition of Adams Mark Hotel in Philadelphia. Processed 50,000 yards of concrete. Very little wear at end of job (shown to the right).

STULZ FABRICATIONS TO ORDER

DREDGE

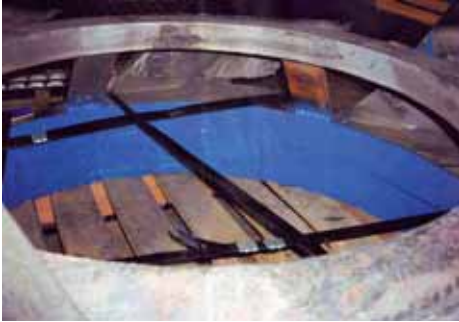

Dredge built with mild steel lasted two months. Customer switched to stainless and then to 400 BHN, each lasted two months, then tried to overlay with ceramic which lasted three days. Finally switched to manganal and is showing no wear after seven months.

IMPACTOR



Impactor used to break up concrete. Manganal blocks in great condition after three years.

SCREEN BUCKET



Bucket fabricated to screen large rock. Manganal bar is a perfect application.

TUFFWEAR

400 AND 500 BRINELL PLATE AND 400 BRINELL HOT ROLLED ALLOY WEAR BARS

Heat Treated for High Hardness, High Tensile Strength
to Resist Severe Abuse and Abrasion

TUFFWEAR IS USED HERE FOR MAINTENANCE AND REPAIR WITHIN THE QUARRY
AND HEAVY CONSTRUCTION INDUSTRIES . . .

- BUCKET LINERS
 - DOZER SKINS
 - GRIZZLY BARS
- PERFORATED PLATE
 - STAGING AREA BINS
 - SCRAPER FLOORS
- SKID PLATES
 - SLIDING CHUTES

STULZ ALLOY-WEAR BARS 390/400 BRINELL Q.T.

WELDABLE

Use Stulz Special Alloy
Welding Electrodes

FORMABLE

Double Grained Plate
Allows For Forming in
Either Direction

UNIFORM HARDNESS

Through Hardened
Quench and Tempered

PHYSICAL PROPERTIES

TUFFWEAR 400

Hardness 390/400 Brinell
Tensile Strength 180,000 Min. PSI

TUFFWEAR 500

Hardness 490/500 Brinell
Tensile Strength 230,000 Min. PSI

TUFFWEAR PLATE

TUFFWEAR 400

390/400 BRINELL
HARDNESS

SIZE	WGT. PER SQ. FOOT (lbs.)
3/16"	7.7
1/4"	10.2
3/8"	15.3
1/2"	20.4
5/8"	25.5
3/4"	30.6
1"	40.8
1-1/4"	51.0
1-1/2"	61.2
2"	81.6

Other sizes on request

TUFFWEAR 500

490/500 BRINELL
HARDNESS

SIZE	WGT. PER SQ. FOOT (lbs.)
1/4"	10.2
3/8"	15.3
1/2"	20.4
3/4"	30.6
1"	40.8

Other sizes on request

SIZE	WGT. PER FOOT (lbs.)	STANDARD LENGTH (ft.)
1/4" x 1"	.85	20
1-1/2"	1.28	20
2"	1.70	20
3"	2.55	20
4"	3.40	20
6"	5.10	20
3/8" x 1"	1.28	20
2"	2.55	20
2-1/2"	3.19	20
3"	3.83	20
4"	5.10	20
5"	6.40	20
6"	7.65	20
8"	10.20	20
1/2" x 1"	1.70	20
1-1/2"	2.55	20
2"	3.40	20
2-1/2"	4.25	20
3"	5.10	20
3-1/2"	5.95	20
4"	6.80	20
5"	8.50	20
6"	10.20	20
8"	13.60	20
3/4" x 2"	5.10	20
2-1/2"	6.38	20
3"	7.65	20
4"	10.20	20
5"	12.75	20
6"	15.30	20
8"	20.40	20
1" x 2"	6.80	20
2-1/2"	8.50	20
3"	10.20	20
4"	13.60	20
5"	17.00	20
6"	20.40	20
8"	27.20	20

SPECIAL SHAPES FOR EARTH MOVING EQUIPMENT

SSHI-C GROUSER BARS - SPECIAL ANALYSIS HIGH CARBON STEEL

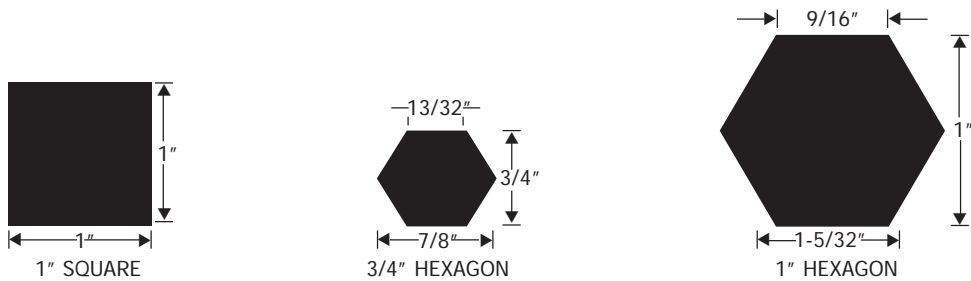

SIZE	STOCK BAR LENGTH	APPROX. WT. PER FOOT (lbs.)
149	10'	1.33
201	10'	1.75
301	10'	2.82
401	10'	3.81
601	10'	5.29
701	10'	6.80
801	18'	10.63
901	14'	14.46
Hex 3/4"	20'/22'	1.7
Hex 1"	20'/21'	3.0
Square 1"	20'	3.4

Can be supplied machine-cut to specified length.

Easily welded to worn grousers with high-tensile, low hydrogen electrodes. May be applied by manual or automatic method using Stulz Special Alloy electrodes.

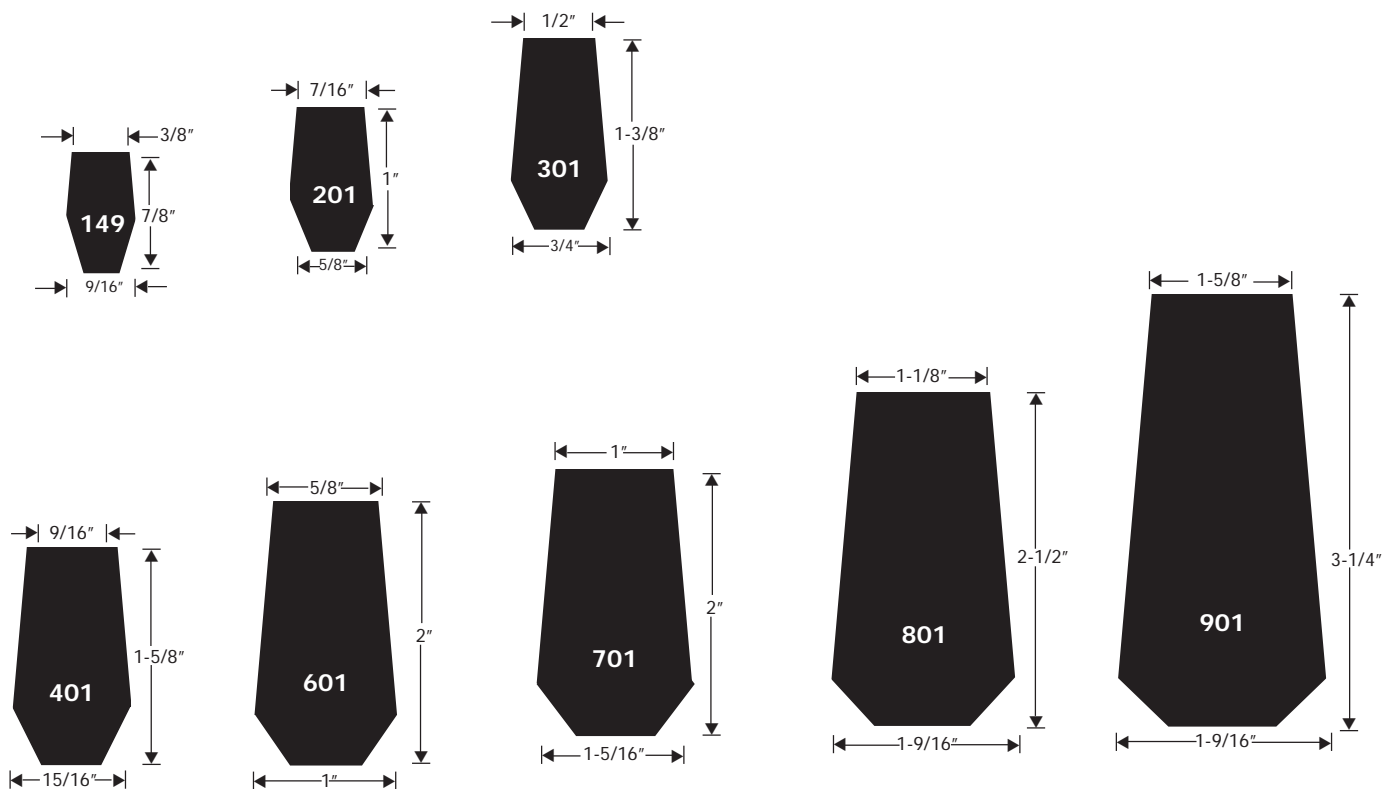

STULZ ALLOY-WEAR BUCKET LIPS

Weld-on Front-End Loader Bucket Lips

HEAT TREATED ALLOY STEEL- 430/500 BRINELL HARDNESS

These Alloy/Wear bucket Lips have high quality heat treatment that makes them last far longer than the ordinary untreated lips. This means less downtime for replacement and more output. Alloy/Wear Bucket Lips stand much more abuse and wear with less weight. A loader does not have to carry extra weight when Alloy/Wear Bucket Lips are used. Custom sizes can be cut to order. Weld with Stulz Special Alloy Welding Electrodes.

SINGLE BEVEL LIPS

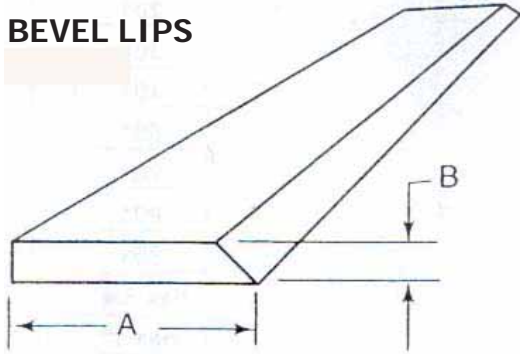

STEP-FIT LIPS

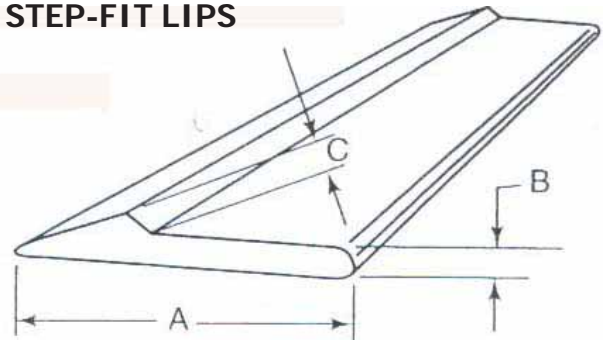

PART NO.	STANDARD LENGTHS	WEIGHT LBS. PER FT.	DIMENSIONS	
			A	B
A3	10 OR 20 FT.	4.5	3"	1/2"
A4	10 OR 20 FT.	6	4"	1/2"
A6	10 OR 20 FT.	10	6"	1/2"
A8	8 OR 10 FT.	19	8"	3/4"
B8	8 OR 10 FT.	25	8"	1"
C8	8 OR 10 FT.	32	8"	1-1/4"
B10	8 OR 10 FT.	31	10"	1"
C10	8 OR 10 FT.	37	10"	1-1/4"
D10	10 OR 12 FT.	49	10"	1-1/2"
C12	10 OR 12 FT.	49	12"	1-1/4"
D12	10 OR 12 FT.	59	12"	1-1/2"
E12	10 OR 12 FT.	68	12"	1-3/4"
F12	10 OR 12 OR 14 FT.	77	12"	2"

PART NO.	STANDARD LENGTHS	WEIGHT LBS. PER FT.	DIMENSIONS		
			A	B	C
SF	8-9-10-11-12 FT.	21	8"	7/8"	1/2"

HEAVY DUTY STEP-FIT LIPS

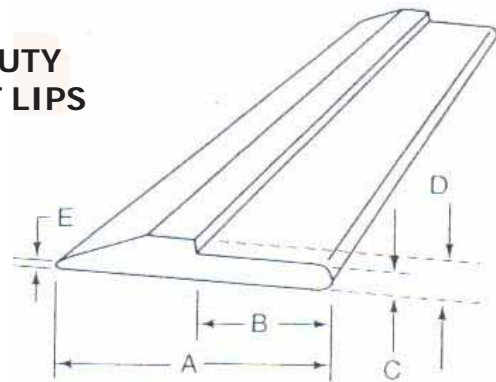

PART NO.	STANDARD LENGTHS	WEIGHT LBS. PER FT.	DIMENSIONS				
			A	B	C	D	E
HDSF	12 FT.	44	10"	5-1/4"	1-1/8"	2-1/4"	7/16"
HDSF	14 FT.	44	10"	5-1/4"	1-1/8"	2-1/4"	7/16"

*Other sizes cut to order



WELDING ELECTRODES FOR HEAVY INDUSTRY

SEMI-AUTOMATIC OPEN ARC WELDING WIRES

STULZ MANGANESE-XL

A high manganese-nickel chrome electrode for joining manganese and building-up parts of manganese, carbon and alloy steels that are subject to extreme shock, impact and abrasion. No peening is required. May be applied multiple pass. Tensile strength 125,000 PSI. Six 10 lb. waterproof containers per carton. Standard length 14".
AC-DC

STULZ 1616 ELECTRODES

All purpose high chromium, high manganese for high strength joining of manganese steel to other alloy steels and for multi-pass build-up for good wear resistance. Cannot be flame cut. Standard length 14".
AC-DC

STULZ UNIVERSAL HARDFACE

All purpose hardsurfacing for heavy industry and mining; for combinations of abrasions and impact. Forgeable. Reasonably resistant to corrosion. Hardness to 45RC. Six 10 lb. waterproof containers per carton. Standard length 14".
AC-DC

STULZ ULTRA HARD - 60

Chrome/silicone carbide. Weld hardness 60 RC in just a single pass. Has good resistance to impact and pressure. Limited to two passes. Six 10 lb. waterproof containers per carton. Standard length 14".
AC-DC

STULZ SPECIAL ALLOY ELECTRODES

Low hydrogen, Iron Powder Electrode which combines a deposit of excellent tensile strength and resistance to cracking under impact. A specially-designed welding electrode for use with Stulz Alloy/Wear products and other low to medium carbon steels. All position. Six 10 lb. waterproof containers per carton. Standard length 14".
AC-DC

STULZ MANGANESE XL- S/A

Used for build-up and replacement of worn manganese steel by semi-automatic method.
7/64", 1/16" and .045 Dia. OPEN ARC

STULZ HARDFACING #12-S/A

For any single and multi-pass hardfacing of manganese, low alloy, and mild steels.
7/64", 1/16" and .045 Dia. OPEN ARC

STULZ #1616-SA

All purpose high chromium, high manganese for high strength joining of manganese steel to other alloy steels and for multi-pass build-up for good wear resistance. Cannot be flame cut.
7/64", 1/16" and .045 Dia. OPEN ARC

STULZ MULTI-LAYER 50 S/A

A hardfacing wire with multi-pass capabilities. A one wire answer to jobs requiring major build-up.
● Can be welded on either carbon or manganese steel.
● A chrome-manganese-Moly analysis with deposit hardness of 45 RC (2 layers) to 50 RD (4 or more layers).
● 7/64" diameter. OPEN ARC

STULZ SPECIAL ALLOY S/A

A specially-designed welding wire for use with Stulz Alloy/Wear products and other low to medium carbon steels.
● Requires shielding gas CO₂ or 75% Argon 25% CO₂ mixture preferred.
● Tensile Strength: 83,000 PSU - Yield Strength: 65,000 PSI
● .045" and 1/16" diameters.

STULZ CHROMIUM WEAR STRIPS

INSTANT HARDFACING **Hardness: 50 RC up to 700F**
Dim.: 1/4" x 1 1/2" x 19 to 20" ● Standard Pkg.: 36 Pcs.



STULZ WEAR PATCHES INSTANT HARDFACING

3/16" Thick ● Hardness: 60 RC

Slotted for easy, quick attachment by welding.



STULZ JUMBO WEAR PATCHES

INSTANT HARDFACING

Hardness: 60 RC

Slotted for easy, quick attachment by welding.

Size	Std. Pkg
1/4" x 3" x 4"	75 pcs
1/4" x 4" x 5"	50 pcs
1/4" x 5" x 7"	25 pcs
3/8" x 4" x 5"	25 pcs
3/8" x 5" x 7"	12 pcs

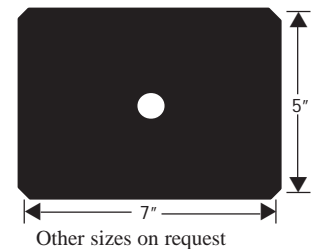

STULZ CORNER WEAR PATCHES

3/16" Thick ● Std. Pkg: 100pcs.



**WE
ACCEPT**



STULZ-SICKLES STEEL CO.

NOTES:

STULZ-SICKLES

SINCE 1916

STEEL COMPANY



STULZ-SICKLES STEEL COMPANY

P.O. BOX 273 • 929 JULIA STREET, ELIZABETH, NJ 07207 • 800-351-1776 • (908) 351-1776 • FAX (908) 351-8231
www.stulzsicklessteel.com

MANGANAL SALES DIVISION

1240 S. LINCOLN STREET, COLTON, CALIFORNIA 92324 • 800-572-5809 • (909) 824-5580 • FAX (909) 824-2137
www.manganal.com